

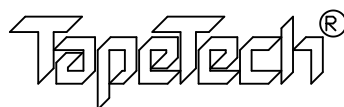

15	CORNER ROLLER ASSY	
	TopoTech <sup>®</sup> on AXIA enterprise	REV E

# (Pre April 2012)

REVISIONS				
ECN	REV	DESCRIPTION	DATE	BY
1039	A	RELEASED	05/00	HM
1184	B	164348 WAS 158348, UPDATE /w F PNs	07/01	MWJ
1231	C	REMOVE HANDLE AND GRIP	10/01	HM
1245	D	REVERT TO REV B CONFIG AND RERELEASE	01/02	HM
1404	E	REPLACE 156042 WITH 151042	04/05	MWJ

	Dwg No.	Part No.	Description	Qty.
ⒹⒸⒷ	01	164348	Handle Assembly	1
Ⓑ	02	150003F	Coupling	1
	03	059143	Cotter Pin, 1/16 x 1/2	1
Ⓑ	04	156001F	Corner Roller Head	1
Ⓑ	05	150004F	Swivel Coupling Pin	1
	06	150008	Thrust Washer	4
	07	809006	Brass Washer	4
	08	159006	Roller Axle, 1/4-20 x 1 1/4 Hex.	4
Ⓑ	09	150011F	Roller Bushing	4
	10	150005	Roller	4
	11	159010	Screw, 8-32 x 3/8 Fil. Hd. Nylock	1
	12	154007	Swivel Assy.	1
	13	150009	Swivel Axle	1
ⒺⒹⒸⒷ	14	151042	Handle Grip, Black	1
	15	123441	Label	1

DRAWN	BY	DATE	CORNER ROLLER ASSY.			
CHKD	HM	05/00				
APPVD	HM	05/05				
ALL DIMENSIONS IN INCHES UNLESS OTHERWISE NOTED			 an  enterprise			
TOLERANCES UNLESS NOTED XX ± 0.010 XXX ± 0.005 ANGLES ± 1/2°						
MATERIAL			SIZE B	SCALE	DWG NO. 15 TT	REV E
ASSEMBLY REF. NO.				SHEET 1 of 2		

# (Pre April 2012)

REVISIONS				
ECN	REV.	DESCRIPTION	DATE	BY
1420	A	RELEASED FOR PRODUCTION	03/05	MWJ
1428	B	159024 (QTY 4) WAS 129061	11/05	MWJ
	C	150004F & 150009 WERE REVERSED ON ASSY VIEW	07/08	MWJ

ITEM NO.	PART NUMBER	DESCRIPTION	exploded view/QTY.
1	156001F	CORNER ROLLER HEAD, NON-LOGO	1
2	151006	STUD	4
3	154007	SWIVEL ASSEMBLY	1
4	150004F	SWIVEL COUPLING PIN	1
5	159023	NYLON WASHER	8
6	151011	INNER ROLLER	4
7	151005	OUTER ROLLER ASSEMBLY	4
8	150009	SWIVEL AXLE	1
9	059143	COTTER PIN	1
10	150003F	COUPLING	1
11	159010	8-32 3/8 FILLISTER HEAD SCREW	1
12	164348	CR HANDLE ASSY, SOLD	1
13	151042	HANDLE GRIP, BLACK, NO LOGO	1
14	159024	RETAINING RING, EXT, 0.25 SHAFT	4

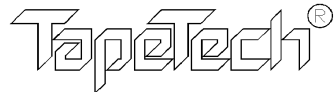
	BY	DATE	CORNER ROLLER			
DRAWN	MWJ	03/05	 <b>an Axia Enterprise</b>			
CHECKED	DJC	07/08				
ALL DIMENSIONS IN INCHES UNLESS OTHERWISE NOTED TOLERANCES UNLESS NOTED .XX ± 0.010"      ANGULAR ±.5° .XXX ± 0.005"			SIZE	SCALE = 1:1	DWG. NO. 15TTE	REV.
MATERIAL :			B			C
			ASSEMBLY REF. NO.			SHEET 1 of 2

# (After April 2012)

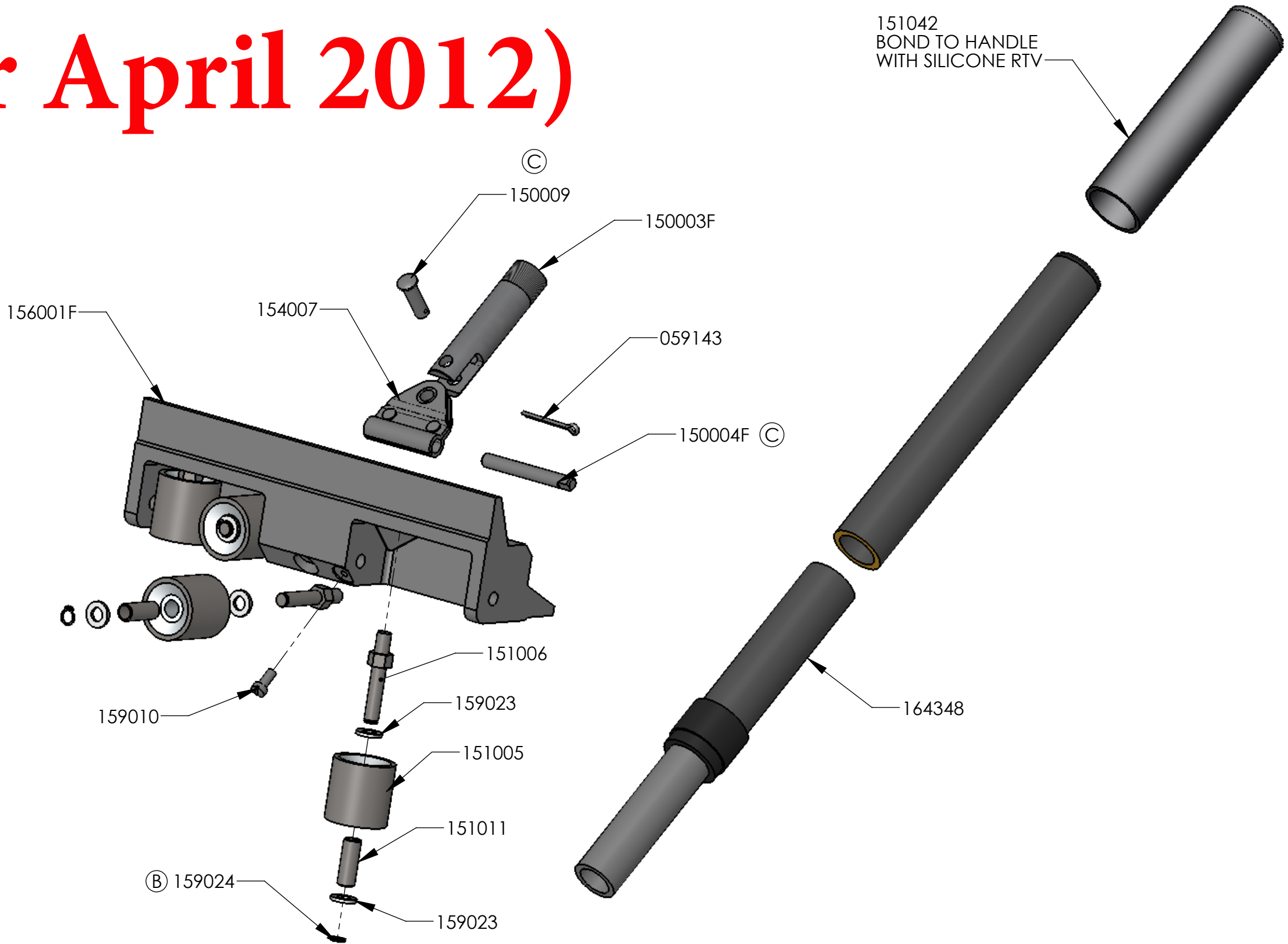

15TTE	CORNER ROLLER	
	<b>Tapetech</b> PROFESSIONAL DRYWALL FINISHING TOOLS	REV. C

# (After April 2012)

REVISIONS				
ECN	REV.	DESCRIPTION	DATE	BY
1420	A	RELEASED FOR PRODUCTION	03/05	MWJ
1428	B	159024 (QTY 4) WAS 129061	11/05	MWJ
	C	150004F & 150009 WERE REVERSED ON ASSY VIEW	07/08	MWJ
1544	D	REPL 151006 AND 159024 WITH NEW STUD ASSY	12/08	MWJ

<u>PART NUMBER</u>	<u>DESCRIPTION</u>	<u>QTY</u>
156001F	CORNER ROLLER HEAD, NO LOGO	1
154007	SWIVEL ASSY	1
150004F	SWIVEL ASSEMBLY	1
159023	NYLON WASHER	8
151011	INNER ROLLER	4
151005	OUTER ROLLER ASSEMBLY	4
150009	SWIVEL AXLE	1
059143	COTTER PIN	1
150003F	COUPLING	1
159010	SCREW, 8-32 x 3/8 FILLISTER HEAD	1
152006	STUD	4
152025	SPACER	4
159026	NUT, LONG	4
159027	WASHER	4
164348	CR HANDLE ASSY	1
151042	GRIP	1

	BY	DATE	CORNER ROLLER			
DRAWN	MWJ	03/05	 <small>PROFESSIONAL DRYWALL FINISHING TOOLS</small>			
CHECKED	DJC	07/08				
<small>ALL DIMENSIONS IN INCHES UNLESS OTHERWISE NOTED TOLERANCES UNLESS NOTED .XX ± 0.010"      ANGULAR ±.5° .XXX ± 0.005"</small>			SIZE B	SCALE = 1:1	DWG. NO. 15TTE	REV. D
MATERIAL :			ASSEMBLY REF. NO.		SHEET 1 of 2	

# (After April 2012)

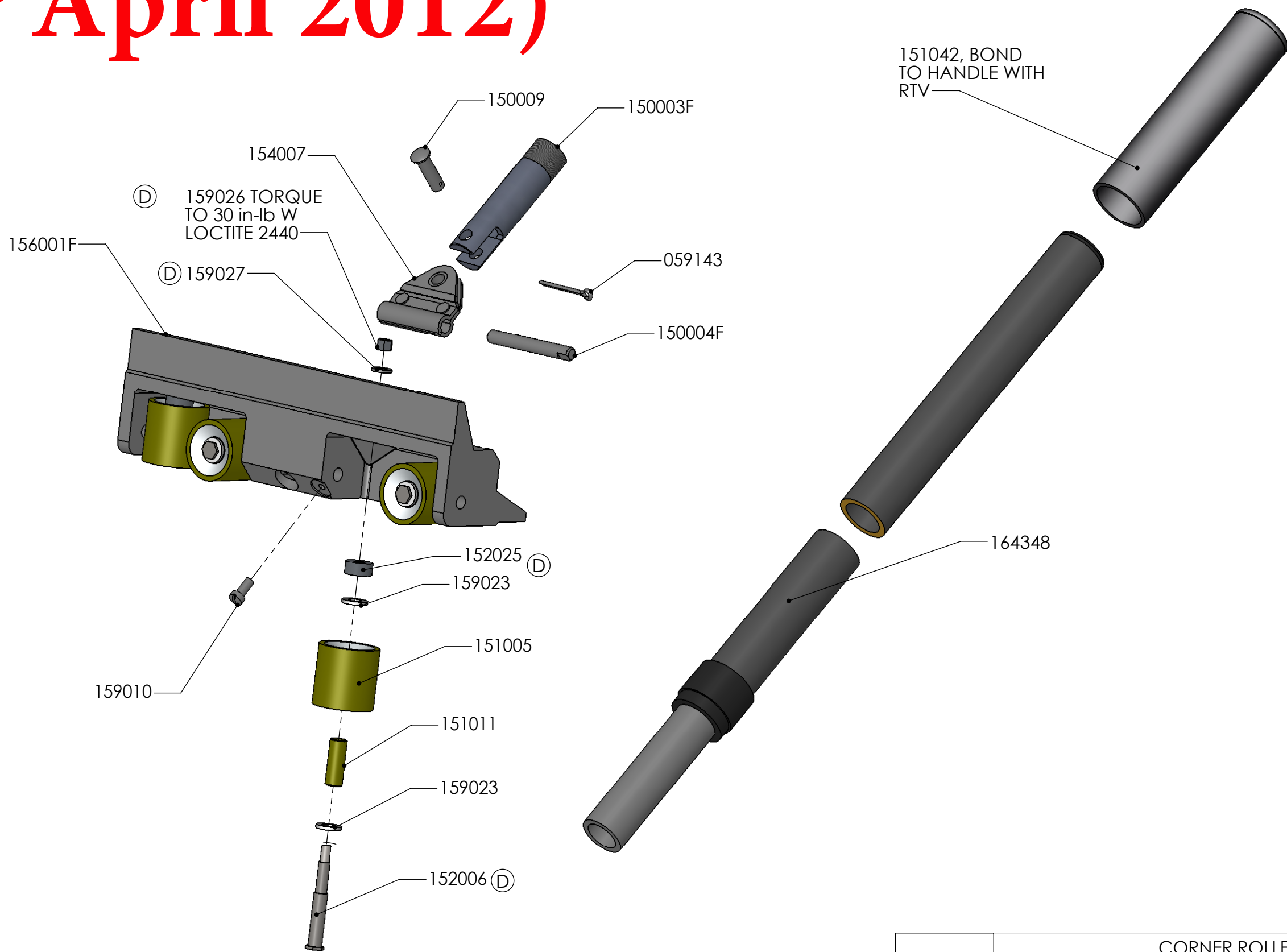

15TTE	CORNER ROLLER	
	<b>TapeTech</b> PROFESSIONAL DRYWALL FINISHING TOOLS	REV. D