

REVISIONS				
ECN	REV.	DESCRIPTION	DATE	APPROVED
	A	RELEASED FOR PRODUCTION	05/13	MWJ
	B	REPL 889018 W 059143 & 499024	03/15	MWJ

P/N	Qty	Description	P/N	Qty	Description
882001G	1	Exterior Tube	880028	1	Compression Spring
882002	1	Profile Extrusion	059156	2	# 4-40 x 5/16 Binding Head Screw
884003B	1	Handle Bracket	889035	7	# 6-32 x 1/4 Slotted Pan Head Screw
889017	1	Conical Spring	882039	1	Spring Housing
882011B	1	Actuator	880042	1	Rubber Grip Handle
882012	1	Actuator-Clip Pin	880053	1	Lock Block
882013	1	Locking Pin	059020	1	# 6-32 x 3/8 Binding Head Screw
889009	1	5/32 x 1 Slotted Spring Pin	882016	1	Guide Plug
059018	1	# 6-32 Locknut	882014	1	Locking Clip
910005	1	Knob	059143	1	Cotter Pin 1/16 X 1/2 SST.
			499024	1	Washer - .188Id X .380Od X .032Thk 18- <sup>ⓑ</sup>
920037	1	Nail Spotter Adapter Assy	603031	2	Nut, Special
880368	2	NS Connector Adapter	609032	2	Screw 10-32 X 3/4 Fl. Hd.

DRAWN		BY	DATE	Nail Spotter Xtender Handle			
CHECKED		MWJ	01/13				
ALL DIMENSIONS IN INCHES UNLESS OTHERWISE NOTED TOLERANCES UNLESS NOTED .XX ± 0.010"      ANGULAR ±.5° .XXX ± 0.005"				 PROFESSIONAL DRYWALL FINISHING TOOLS			
MATERIAL: N/A							SIZE B
				ASSEMBLY REF. NO. N/A		SHEET 1 of 3	

NOTES:  
1. LOCTITE (BLUE) TO BE USED ON SCREW THREADS AS NOTED.

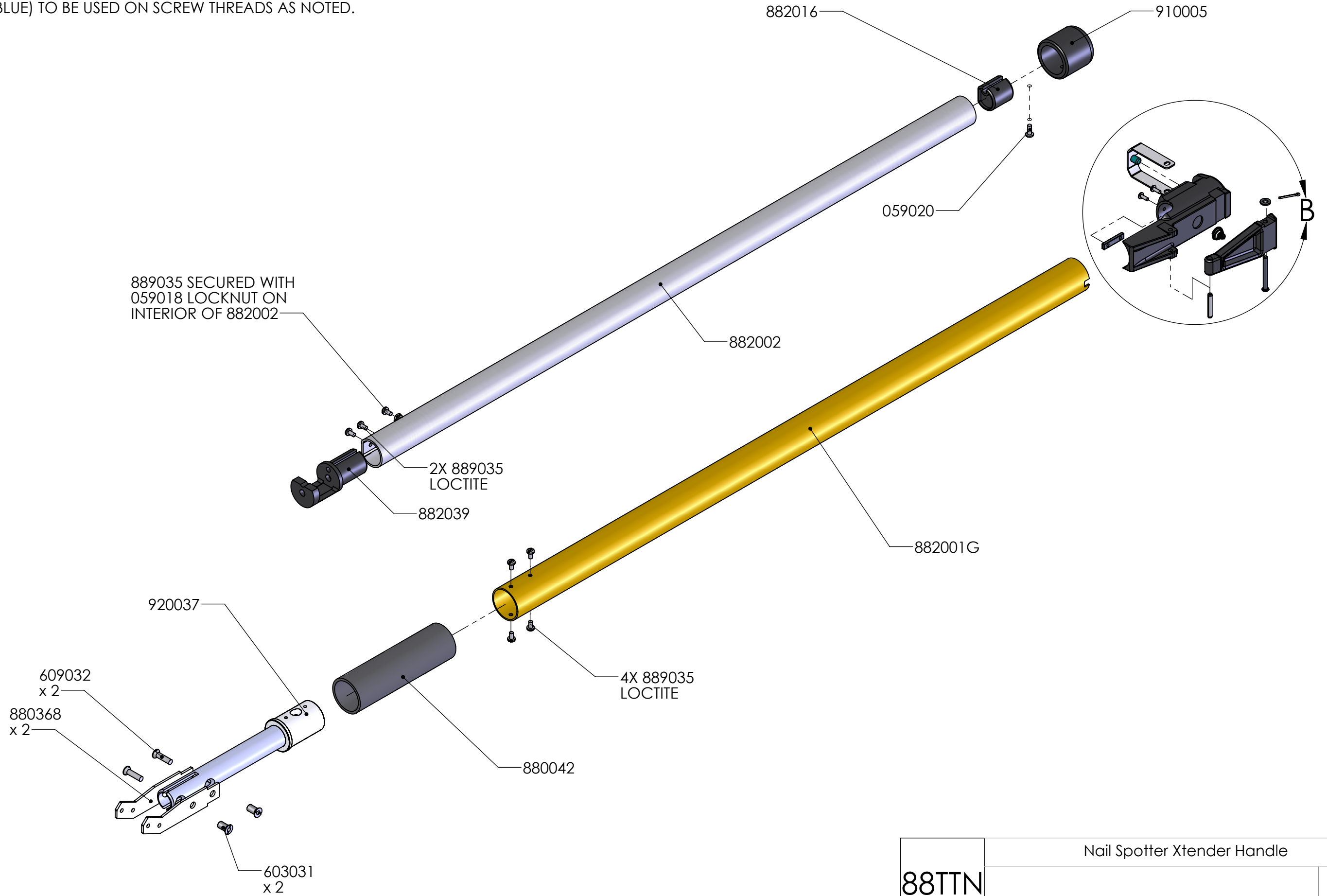

88TTN	Nail Spotter Xtender Handle	
		REV. B

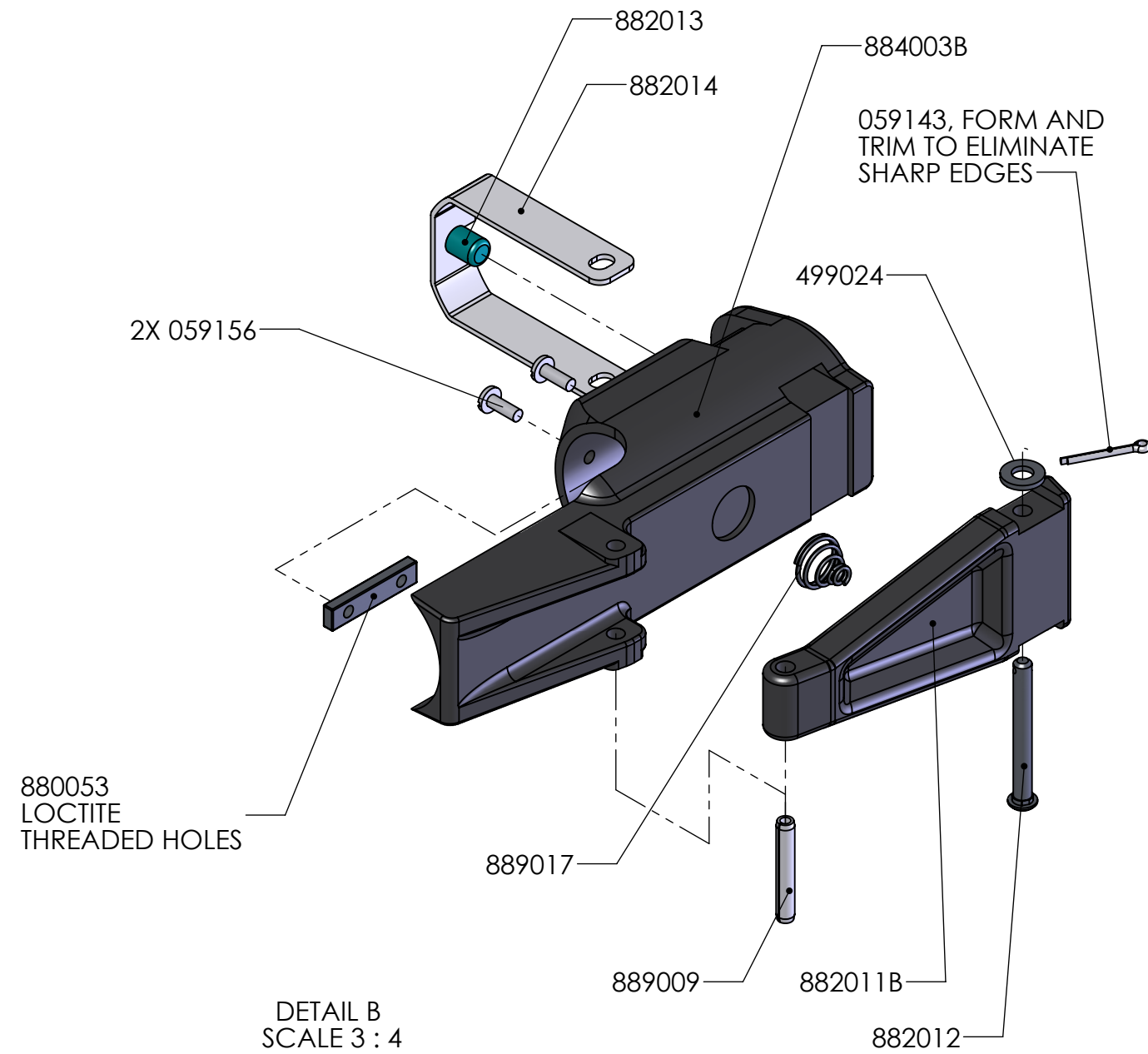

88TTN	Nail Spotter Xtender Handle	
	 <small>PROFESSIONAL DRYWALL FINISHING TOOLS</small>	REV. B